

R. F. DARLING.
TURNING LATHE.

No. 400,550.

Patented Apr. 2, 1889.

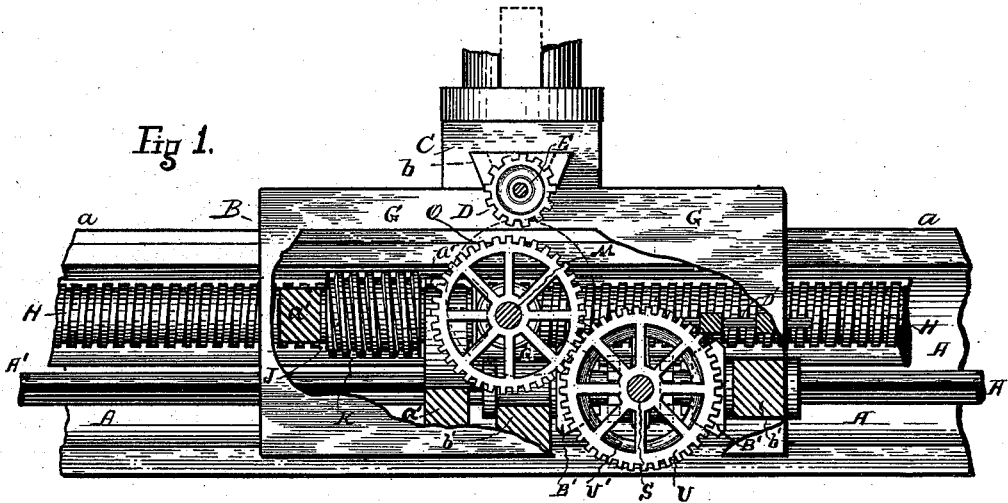

Fig 2.

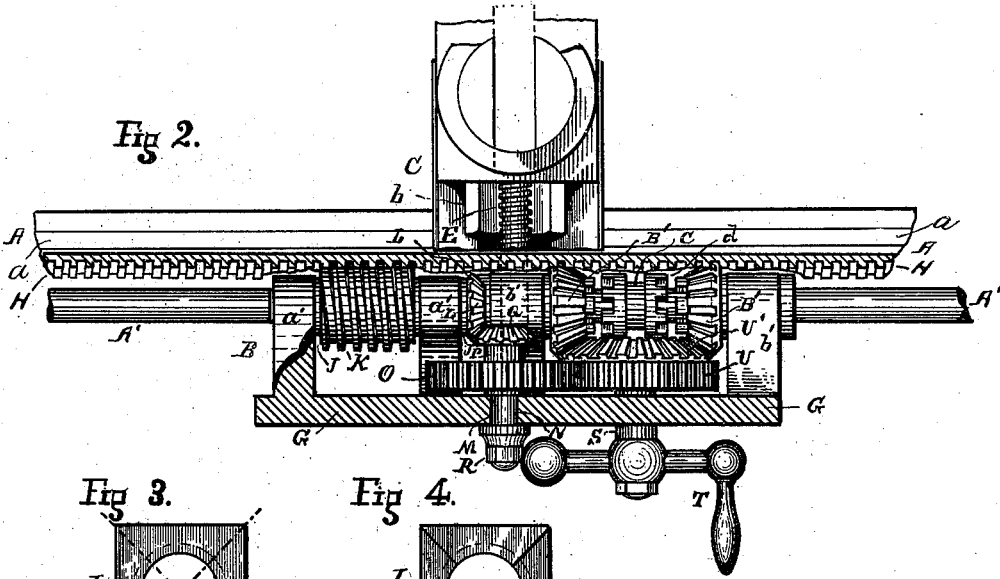

Fig 3.

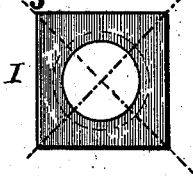

Fig 4.

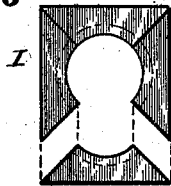
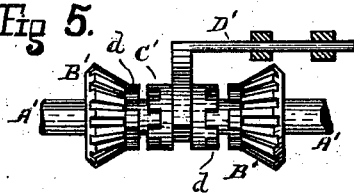

Fig 5.



Witnesses.

Frank Holleran
Robert Furness

Inventor.

Robert F. Darling
By *F. F. Warner*
his atty

R. F. DARLING.
TURNING LATHE.

No. 400,550.

Patented Apr. 2, 1889.

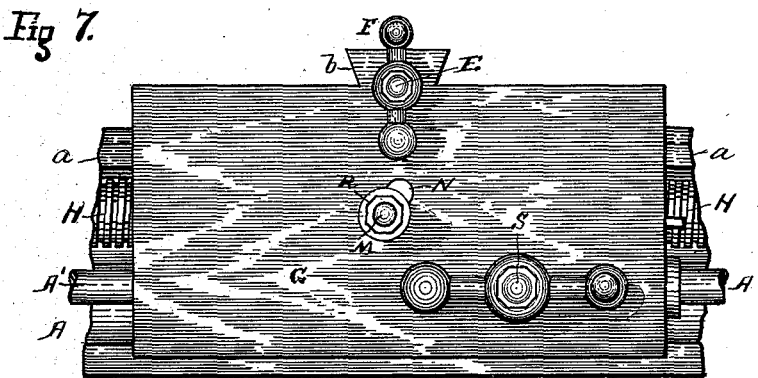
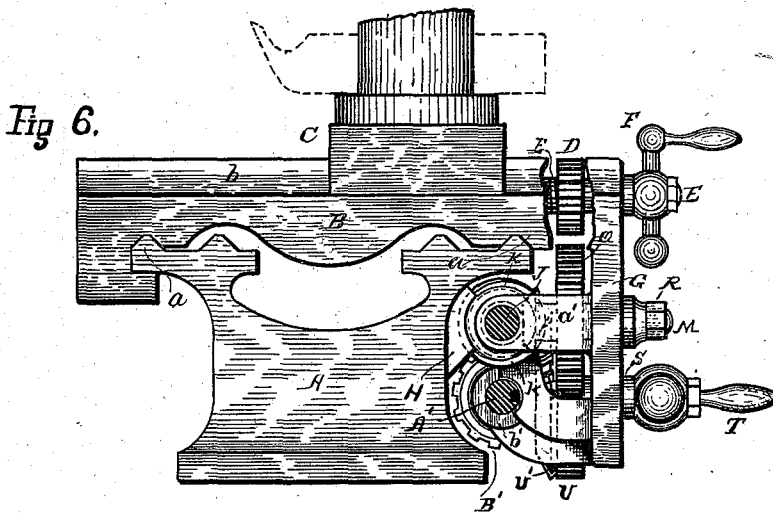

Witnesses.

Frank Holleran.
Robert Furness

Inventor.

Robert F. Darling
By F. F. Warner
his atty

R. F. DARLING.
TURNING LATHE.

No. 400,550.

Patented Apr. 2, 1889.

Fig 8.

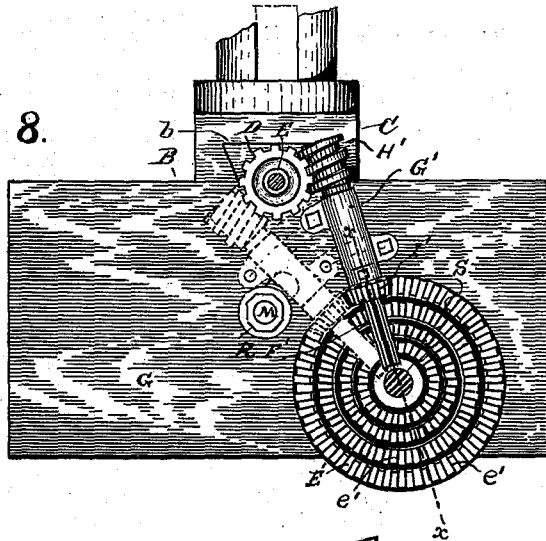
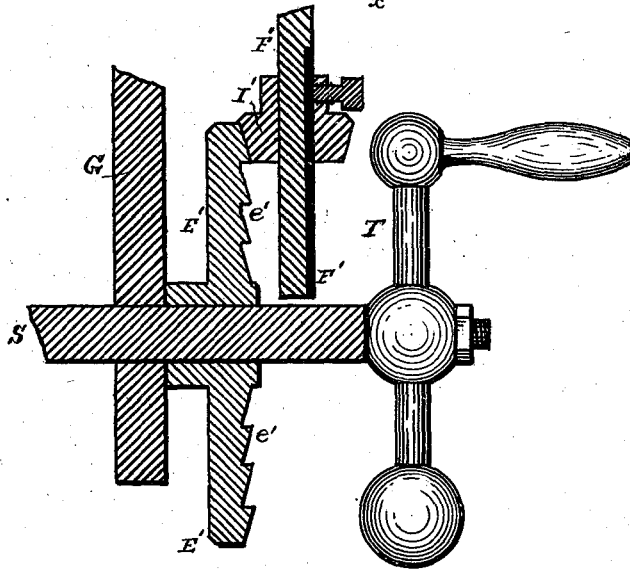

Fig 9.



Witnesses.

Frank Holleran.
Robert Furniss

Inventor.

Robert F. Darling
By J. F. Warner.
his atty.

UNITED STATES PATENT OFFICE.

ROBERT F. DARLING, OF SENECA FALLS, NEW YORK.

TURNING-LATHE.

SPECIFICATION forming part of Letters Patent No. 400,550, dated April 2, 1889.

Application filed July 31, 1888. Serial No. 281,568. (No model.)

To all whom it may concern:

Be it known that I, ROBERT F. DARLING, a citizen of the United States, and a resident of Seneca Falls, in the county of Seneca and State of New York, have invented certain new and useful Improvements in Lathes, of which the following is a specification.

My invention relates to that class of lathes for machines usually employed in iron workings for turning, boring, thread-cutting, and similar operations.

My principal purpose is to improve the means employed for controlling and effecting the feed movement. I also aim to improve machines of this class in other respects, all of which will hereinafter be more fully explained.

The distinctive features of my invention are set forth in my several claims; but to enable others more fully to understand my improvements I will proceed to describe the same particularly, reference being had in so doing to the accompanying drawings, in which—

Figure 1, Sheet 1, is a front elevation of such parts of a lathe of the class referred to as it may be necessary to show in order to explain my invention. Fig. 2, Sheet 1, is a top or plan view of the principal parts represented in Fig. 1. Figs. 3 and 4, Sheet 1, are details representing the manner in which I proceed in order to construct the feed-rack. Fig. 5, Sheet 1, is a detail showing more fully the means employed for shifting the reversing-clutch. Fig. 6, Sheet 2, is an end view of a lathe embodying my improvements. Fig. 7, Sheet 2, is a front view of the same, showing more fully the apron and the parts appearing in front of the same than the said parts are shown in Fig. 1. Fig. 8 is a front elevation or view showing the means employed for turning cylinders having variable diameters. Fig. 9 is a section in the plan of the line *x x*, Fig. 8, enlarged.

Like letters of reference indicate like parts. I have not attempted to represent either the head-stock or the tail-stock, as my improvements do not relate particularly thereto.

A represents the frame or bed of the lathe. *a a* are carriage-ways, and B is the carriage. C is the tool-block or tool-carrier, and *b* is a way on which it moves across the carriage.

D is a pinion mounted rigidly on the cross-feed screw or worm E, on the outer end of which is a crank or handle, F, for rotating the same by hand. G is the apron which, as usual, is in rigid connection with the carriage B.

H is the rack, which is rigidly attached to the frame or bed. This rack is a peculiarity of my invention, and may be constructed in various ways, so far as relates to the operation of making. I deem it preferable to construct it by casting a block upon a form consisting of a cylinder or core. This block I tap out, after which I cut the same, as indicated by the dotted or broken lines in Fig. 3, wherein I represents the nut or block referred to, and which, as will be perceived, is thus divided into four like parts. These parts I separate and arrange end to end longitudinally in the same line, the spirals being outward. A rack four times the length of the block or nut and having an inwardly-curved face on which there are inclined grooves and ribs arranged alternately is thus formed, and this rack I apply to the frame or bed rigidly and in substantially the position indicated in Figs. 1 and 6.

J is a shaft arranged parallel to the said rack and turning in suitable bearings, *a' a'*, extending from the carriage. K is a comparatively short worm or spiral mounted rigidly on the shaft J and engaging the rack.

L is a beveled pinion rigidly applied to one end of the shaft J.

M is a shaft passing horizontally through a curved slot, N, in the apron.

O is a cog-wheel turning on the shaft M.

P is a sleeve or hub rigidly attached to the wheel O, and Q is a bevel-gear rigidly attached to the said hub or sleeve and adapted and arranged to engage the gear-wheel L.

R is a nut on the outer end of the shaft M, it being understood that the wheel O or its hub or sleeve is prevented from slipping toward the inner end of its shaft in any suitable or well-known way, and that the said shaft is threaded to receive the nut R. It will now be perceived that the said shaft and the parts mounted thereon may be raised by loosening the said nut and secured firmly in their altered position by tightening the said

nut. The slot N, through which the said shaft passes, is of such size and form as to permit the wheel O to be raised into engagement with the pinion D, thus carrying the gear-wheel Q from engagement with the wheel L. It may here be explained that the carriage B will now be firmly held in place, and that the material being operated upon will no longer be affected by any longitudinal-feed movement. This result follows, for the reason that the worm K is in engagement with the rack H and out of engagement with the longitudinal feed-gearing, as will hereinafter more fully appear. It may also be here stated that the wheels O and D, when engaged, transfer the feed-movement to the cross-feed, as will also be further explained.

S is a shaft having a bearing in the apron. T is a crank or handle on the said shaft.

U is a cog rigidly mounted on the shaft S and engaging the wheel O. The wheel U carries a mitered or beveled cog, U'.

A' is a shaft turning in suitable bearings, b' b', extending from the carriage.

B' B' are mitered wheels engaging the cog-wheel U' and through which the shaft A' passes freely.

C' is a sliding toothed clutch keyed or splined to the shaft A', so as to be capable of sliding thereon, but turning therewith. This clutch is arranged between the wheels B' B', and these wheels are toothed, as shown at *d d*, to be engaged by the said clutch alternately, according to the position of the latter.

D' is a forked arm. The forked end enters an annular groove in the clutch C. In the example shown the arm D' slides in fixed supports, and is angular in form, as shown in Fig. 5; but it may be pivoted or differently formed, as may be deemed best.

For the purpose of connecting the longitudinal-feed gear with the cross-feed gear mechanically, so as to automatically control both feed-movements at the same time for producing tapering work or to make variable the diameter of cylinders being operated upon, I employ means substantially such as I will now describe.

E' is a disk mounted on the shaft S removably, but so as to be rotated therewith.

e' e' are radial teeth or gear arranged in concentric circles one within the other upon the outer side or face of the said disk.

F' is a shaft turning in a sleeve or bearing, G', applied to the outer side of the apron.

II' is a worm or spiral gear mounted rigidly on the shaft F' and engaging the pinion D.

I' is a beveled cog or pinion keyed to the shaft F', so as to be capable of being adjusted thereon to engage either series of the teeth e' e', it being understood that the teeth of the pinion I' are adapted for engagement with the different series of teeth e' e', according as to which series the said pinion may be set to engage.

It will be observed, on reference to Fig. 8,

that the worm or spiral II', as there shown in full lines, engages one side of the pinion D. The bearing G', however, may be shifted, so that the said worm or spiral will be in engagement with the opposite side of the said pinion, and so that the pinion I' will remain in engagement with the toothed disk E', as indicated by the dotted or broken lines shown in the figure last referred to. To shift the pinion I' from one series of teeth to another, I loosen or temporarily detach the bearing G', which is also capable of being shifted to the position referred to.

It will be perceived that when the clutch is in engagement with one of the wheels B' B' that the gearing then driven by the said clutch will be rotated in one direction and in the opposite direction when the said clutch engages the other of the said wheels, while the shaft A' revolves continuously in the same direction. When the said clutch engages neither of the said wheels, the carriage may be moved to any position desired by means of the crank T. It is to be observed, however, that either the longitudinal-feed movement or the cross-feed movement can be controlled in this manner, according to the wheels engaged alternately, by shifting the position of the shaft M, it being understood that the wheel O is always in engagement with the wheel U and that the shaft A' represents the driving-shaft. It will also be perceived from the foregoing description that as the shaft S is rotated a rotary movement will be imparted through the medium of the shaft F' and the gearing thereon, so that the cross-feed movement will operate simultaneously with the longitudinal-feed movement, and the tool, therefore, will be so moved as to produce tapering work.

The degree of taper may be varied by shifting the pinion I' from one to the other series of teeth, e' e', and the direction of the cross-feed movement may be reversed by shifting the worm II' from one to the other side of the pinion D, as described. Cylinders may thus be turned, so that when finished the diameter of any one will be variable or have a tapering surface, and more than one tapering portion may be so made on any one cylinder. Similar variations may be made in boring.

Having thus described my invention, what I claim as new, and desire to secure by Letters Patent, is—

1. The combination, in the longitudinal-feed mechanism of a lathe, of a short or comparatively short rotary screw, worm, or spiral turning in suitable bearings extending from the carriage, and a long or comparatively long rack engaging the said screw and secured to the frame or bed of the lathe, substantially as and for the purpose specified.

2. The combination, in the longitudinal-feed mechanism of a lathe, of a short or comparatively short screw, worm, or spiral turn-

ing in suitable bearings extending from the carriage, a long or comparatively long rack engaging the said screw and secured to the frame or bed of the lathe, and shifting-gear
5 constituting a part of the longitudinal-feed mechanism and arranged to engage alternately a gear or pinion on the shaft or spindle of the said worm and a pinion or gear in the cross-feed mechanism, substantially as
10 and for the purpose specified.

3. In the feed mechanism of a lathe, the hereinbefore-described means for reversing the feed-movement, the said means consisting of the shaft A', the bevel-gears B' B', turning
15 loosely on the said shaft and having clutch-engaging teeth, the sliding clutch C', mounted on and turning with the said shaft and arranged between the said gears, the wheel or gear U', engaging the said bevel-gears, an arm
20 for shifting the said clutch, and the apron of the lathe, substantially as and for the purpose specified.

4. A lathe in which the longitudinal-feed movement and the cross-feed movement are produced independently by means of a shifting-gear in continuous engagement with driving-gear constituting a part of the means for
25 producing both the said movements, and alternately in engagement with the gear directly employed for moving the carriage and the gear for moving the tool-block, substantially as and for the purpose specified.
30

5. A rack made in sections arranged end to end in a line and having an inwardly-curved
35 outer face on which are inclined alternate

grooves and ribs, in combination with the frame or bed of a lathe and the carriage-moving mechanism, substantially as and for the purpose specified.

6. A lathe in which the longitudinal-feed
40 gearing and the cross-feed gearing are combined with supplemental-feed gearing for simultaneously operating the longitudinal-feed gear and the cross-feed gear, substantially as and for the purpose specified.
45

7. The combination, in a lathe, of the wheel D, constituting a part of the cross-feed gearing, the gears H' and I' and their shaft, the gear E', having thereon one or more sets of teeth, e e, the latter being in operative
50 engagement with the wheel D through the medium of the gears H' and I', and the longitudinal-feed gearing, substantially as and for the purpose specified.

8. The combination, in a lathe, of the wheel
55 D, constituting a part of the cross-feed gearing, the gears H' and I' and their shifting-shaft F', the gear E', having thereon one or more sets of teeth, e' e', the latter being in operative engagement with the wheel D
60 through the medium of the gears H' and I', and the longitudinal-feed gearing, substantially as and for the purpose specified.

Signed at Seneca Falls, in the county of Seneca and State of New York, this 26th day
65 of July, A. D. 1888.

ROBERT F. DARLING.

Witnesses:

JASPER N. HAMMOND,

FRANK HOLLERAN.